

DIRECT INJECTION (DI) ENGINES OR OPEN COMBUSTION CHAMBER ENGINES

The open chamber design can be classified as follows:

- Semiquiescent or low swirl open chamber
- Medium swirl open chamber
- High swirl open chamber ('M' type).

SEMIQUIESCENT OR LOW SWIRL OPEN CHAMBER

- In this type of engine, mixing the fuel and air and controlling the rate of combustion mainly depend upon the injection system.
- The nozzle is usually located at the centre of the chamber.
- It has a number of orifices, usually six or more, which provide a multiple-spray pattern.
- Each jet or spray pattern covers most of the combustion chamber without impinging on the walls or piston.
- The contour of the inlet passage way does not encourage or induce a swirl or turbulence, so the chamber is called quiescent chamber.
- However, the air movement in the chamber is never quiescent, so it is better to call the chamber a semi-quiescent chamber.

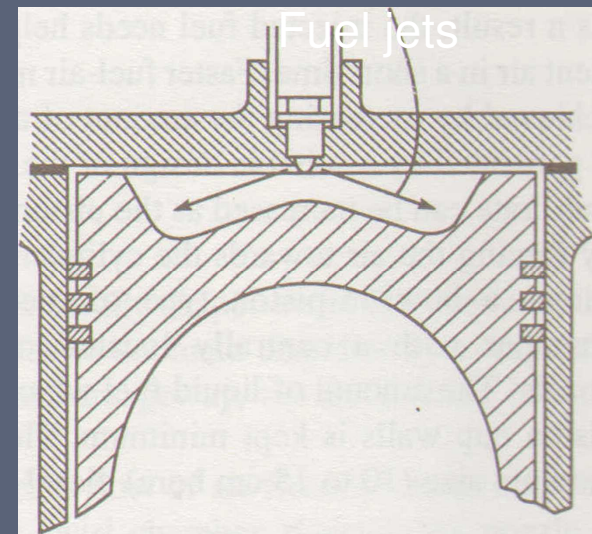

ME2041 *Advanced Internal Combustion Engines*

SEMIQUIESCENT OR LOW SWIRL OPEN CHAMBER

- In the largest size engines where the mixing rate requirements are least important, the semi-quiescent direct injection systems of the type shown in Figure are used. The momentum and energy of the injected fuel jets are sufficient to achieve adequate fuel distribution and rates of mixing with air.
- Any additional organized air motion is not required.
- The chamber shape is usually a shallow bowl in the crown of the piston.
- If the engine is run at low speeds, the possibility of knock is remote, since the fuel can be burned more or less in time with the injection. Hence cheaper fuels can be burned and low combustion pressures can be held. Low combustion temperatures, and low turbulence and swirl reduce heat loss to the coolant.

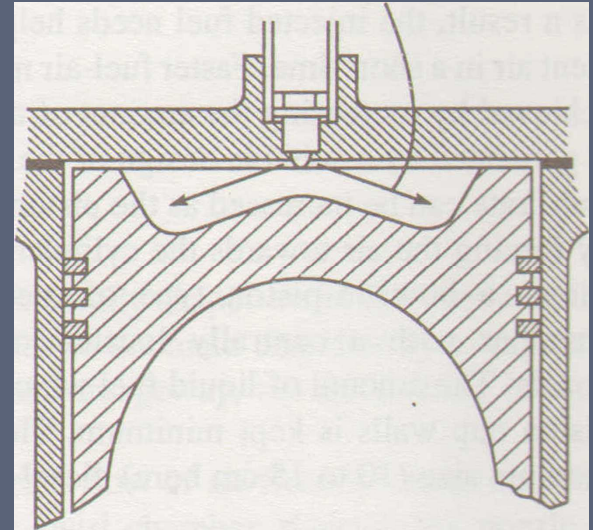

The advantages of the open chamber design with a slow speed engine are as follows:

1. The specific fuel consumption is less, because of the following reasons:

The fuel is burned close to TDC because the time in degree crank angle is long.

It is an approach towards achieving the Otto cycle efficiency.

The air/fuel ratio is high, therefore, combustion should be relatively complete with an approach towards the air standard efficiency.

Percentage heat loss is reduced. It is an approach towards adiabatic combustion.

Following are the possible reasons:

Either low swirl or low turbulence

Low surface-to-volume ratio of an undivided chamber

Low overall combustion temperatures.

2. Starting is relatively easier. It is because of low heat losses.

3. Less heat is rejected to the coolant and to the exhaust gases. It requires smaller radiator and pumps. The life of the exhaust valve is increased.

For small for high f systems h divided

4. The engine is quiet and provides relative freedom from combustion noise.

5. The residual fuels can be burned. It favours the operation of two-stroke engines.

MEDIUM SWIRL OPEN CHAMBER

- As the engine size decreases and the speed increases, the quantity of fuel injected per cycle is reduced and the number of holes in the nozzle is necessarily less (usually 4).
- As a result, the injected fuel needs help in finding sufficient air in a short time.
- Faster fuel-air mixing rates can be achieved by increasing the amount of air swirl. Air swirl is generated by a suitable design of the inlet port.
- The air swirl rate can be increased as the piston approaches TDC by forcing the air towards the cylinder axis.

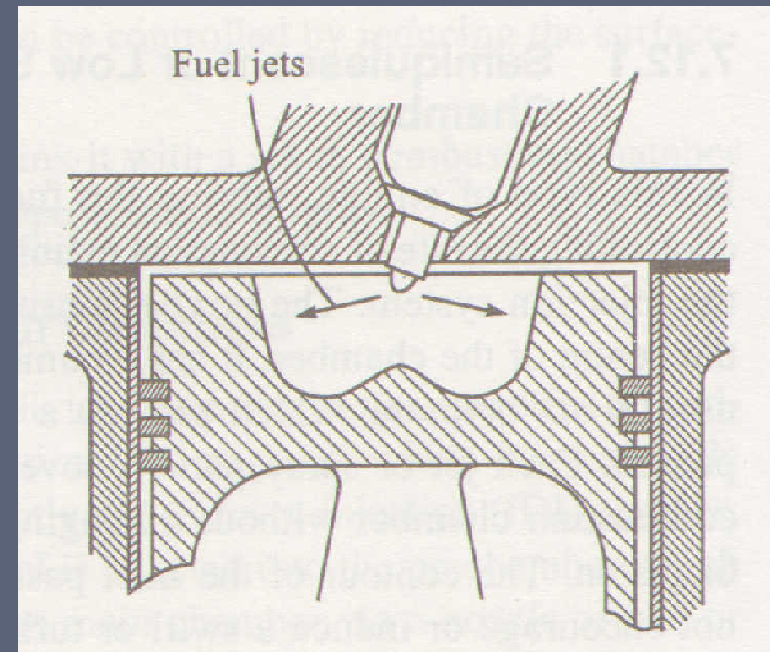
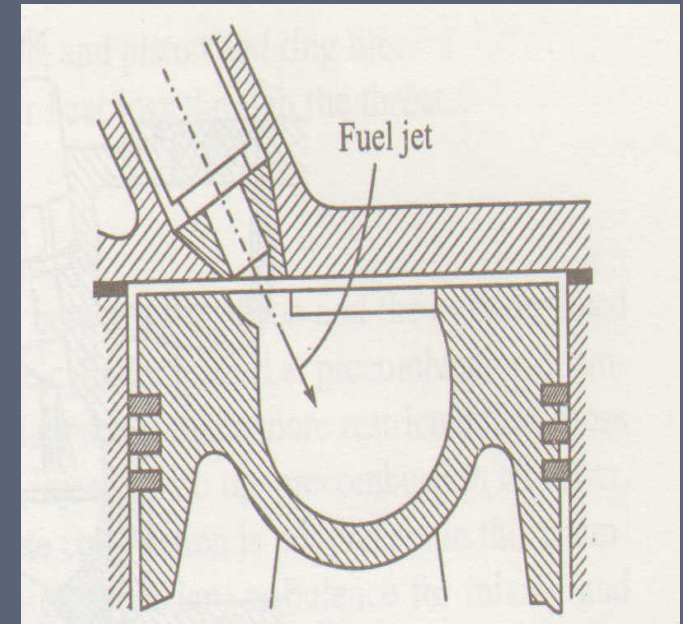

Figure shows a bowl-in-piston type of medium swirl open chamber with a centrally located multihole injector nozzle. The amount of liquid fuel which impinges on the piston cup walls is kept minimum. This type is used in medium size (10 to 15 cm bore) diesel engines.

HIGH SWIRL OPEN CHAMBER

- Spiral intake ports produce a high speed rotary air motion in the cylinder during the induction stroke.
- Here, a single coarse spray is injected from a pintle nozzle in the direction of the air swirl, and tangential to the spherical wall of the combustion chamber in the piston.
- The fuel strikes against the wall of the spherical combustion chamber where it spreads to form a thin film which will evaporate under controlled conditions.
- The air swirl in the spherically shaped combustion chamber is quite high which sweeps over the fuel film, peeling it from the wall layer by layer for progressive and complete combustion. The flame spirals slowly inwards and around the bowl, with the rate of combustion controlled by the rate of vaporization
- In practice, this engine gives good performance even with fuels of exceedingly poor ignition quality. Its fuel economy appears to be extremely good for an engine of small size. Because of the vaporization and mixing processes, the 'M' engine is ideally suited as a multi-fuel engine.



INDIRECT-INJECTION (IDI) ENGINES OR DIVIDED COMBUSTION CHAMBER ENGINES

For small high speed diesel engines such as those used in automobiles, the inlet generated air swirl for high fuel-air mixing rate is not sufficient.

Indirect injection (IDI) or divided chamber engine systems have been used to generate vigorous charge motion during the compression stroke.

The divided combustion chamber can be classified as:

- a) Swirl or turbulent chamber
- b) Precombustion chamber
- c) Air and energy cells.

SWIRL OR TURBULENT CHAMBER

The swirl chamber design is shown in Figure. The spherically shaped swirl chamber contains about 50 per cent of the clearance volume and is connected to the main chamber by a tangential throat offering mild restriction. Because of the tangential passageway, the air flowing into the chamber on the compression stroke sets up a high swirl.

During compression the upward moving piston forces a flow of air from the main chamber above the piston into the small antechamber, called the swirl chamber, through the nozzle or orifice. Thus, towards the end of compression, a vigorous flow in the antechamber is set up. The connecting passage and chamber are shaped so that the air flow within the antechamber rotates rapidly. Fuel is usually injected into the antechamber through a pintle nozzle as a single spray.

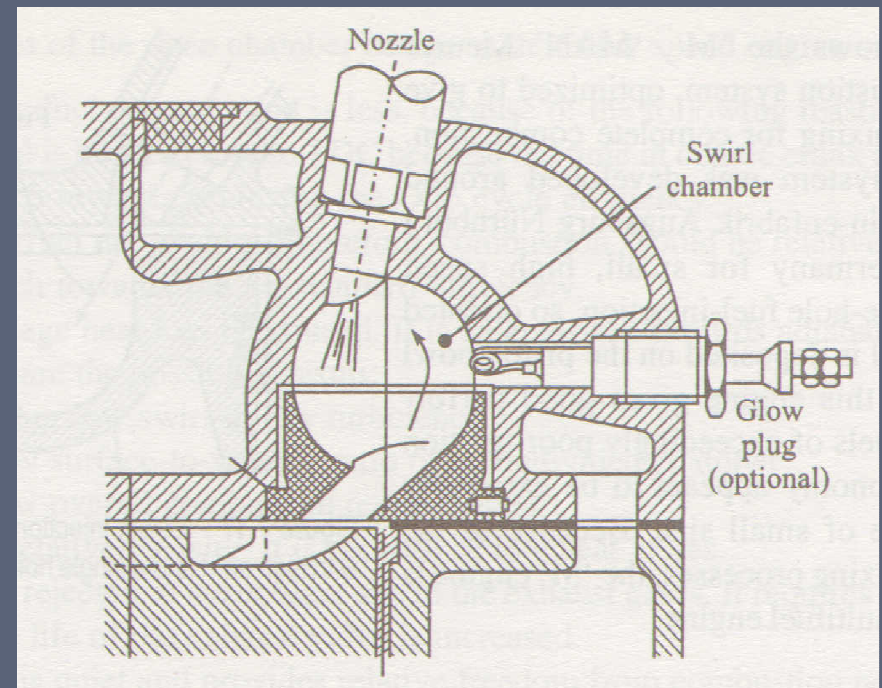

SWIRL OR TURBULENT CHAMBER

In some cases sufficient air may be present in the antechamber to burn completely all but the overload quantities of the fuel injected.

The pressure built up in the antechamber by the expanding burning gases forces the burning and the unburned fuel and air mixtures back into the main chamber, where the jet issuing from the nozzle entrains and mixes with the main chamber air, imparting high turbulence and therefore further assisting combustion.

The glow plug shown on the right of the antechamber in Figure is a cold starting aid.

Since the antechamber is small, deep penetration of the spray is not required. Since the swirl is high, a single hole nozzle is sufficient, although a well atomized fuel spray is desirable. A pintle type nozzle offers these qualities.

The advantages of the indirect injection swirl chamber over the open chamber are as follows:

- Higher speed, brake mean effective pressure and power with less smoke are feasible. It is because of:
 - Higher volumetric efficiency—since the nozzle is at the side, there is more room for the larger intake and exhaust valves.
 - Shorter delay period—since the antechamber is compact and the air swirl in the chamber is very high.
- Less mechanical stress and noise. It is because of the lower rate of pressure rise and the lower maximum pressure in the main chamber due to the throttling effect of thro
- Less maintenance—since the pintle nozzle is self-cleaning and the mechanical stress is less.
- Wider range of fuels can be used. It can serve as a multi-fuel engine with minimal changes.
- Smoother and quieter idling—since matching of small air supply with the small fuel supply is possible. Cleaner exhaust resulting in less air pollution.

The disadvantages of the IDI swirl chamber over the open chamber are as follows:

Higher specific fuel consumption resulting in poorer fuel economy. It is because of greater heat losses and pressure losses through the throat which result in lower thermal efficiency and higher pumping losses.

The flow of combustion gases through the throat leads to thermal cracks in the cylinder head and creates sealing problems.

Cylinder construction is more expensive.

More thermal energy is lost to the exhaust gases. It may decrease the life of the exhaust valve which will run hotter and increase cracking and sealing problems of the exhaust manifold.

PRECOMBUSTION CHAMBER

- Here also the chambers are divided into two parts, one between the piston and the cylinder head (i.e. the main chamber) and the other, smaller one, in the cylinder head (i.e. pre-combustion chamber) as shown in Figure.
- Comparatively small passageways, made more restricted than those in a swirl chamber, connects the two chambers.
- Fuel is injected into the pre-combustion chamber, and under full-load conditions sufficient air for complete combustion is not present in this chamber.
- The pre-combustion chamber is used to create a high secondary turbulence for mixing and burning the major part of the fuel and air.
- Partial combustion of the fuel discharges the burning mixtures through small passage-ways into the air in various parts of the main combustion chambers where the combustion is completed

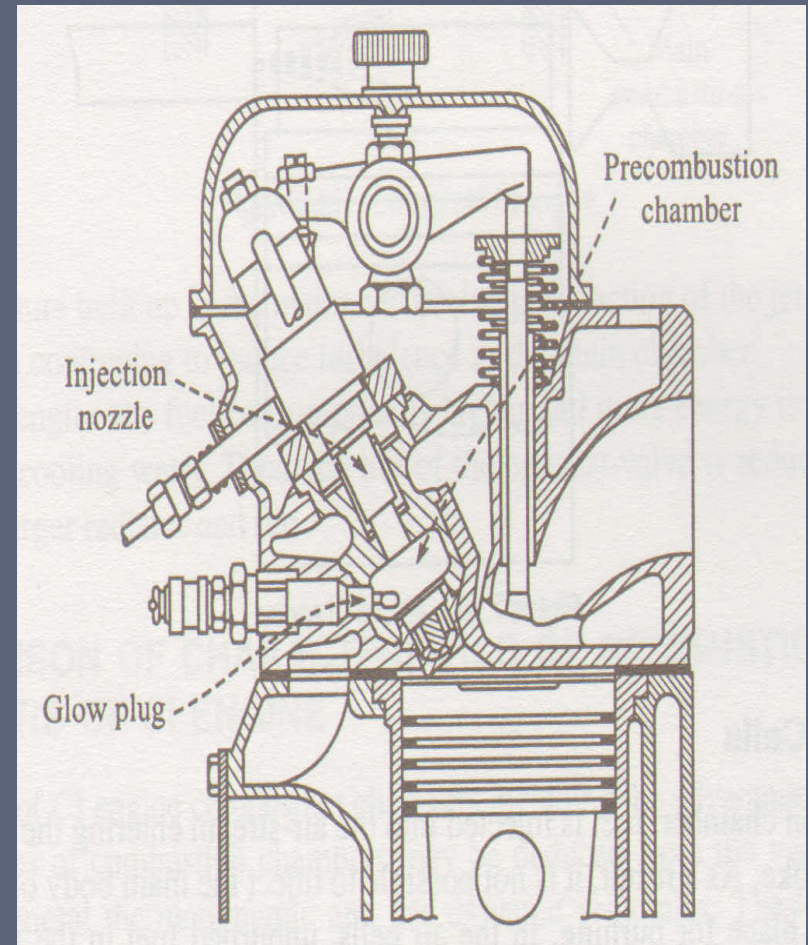

PRECOMBUSTION CHAMBER

- The pre-combustion chamber contains 20-30% of clearance volume (Versus 50% or higher in swirl combustion chambers) with one or more outlets leading to main combustion chamber).
- The passageways may be oriented to create primary turbulence in the pre-combustion chambers.
- Fuel is injected by a single open nozzle with one large orifice to obtain a jet with a concentrated core.
- This type of combustion chamber produces a smooth combustion process but has high fluid friction and heat transfer losses.
- The advantages and disadvantages of the pre-combustion chamber relative to open chamber type are, in general, the same as those described for the swirl chamber.

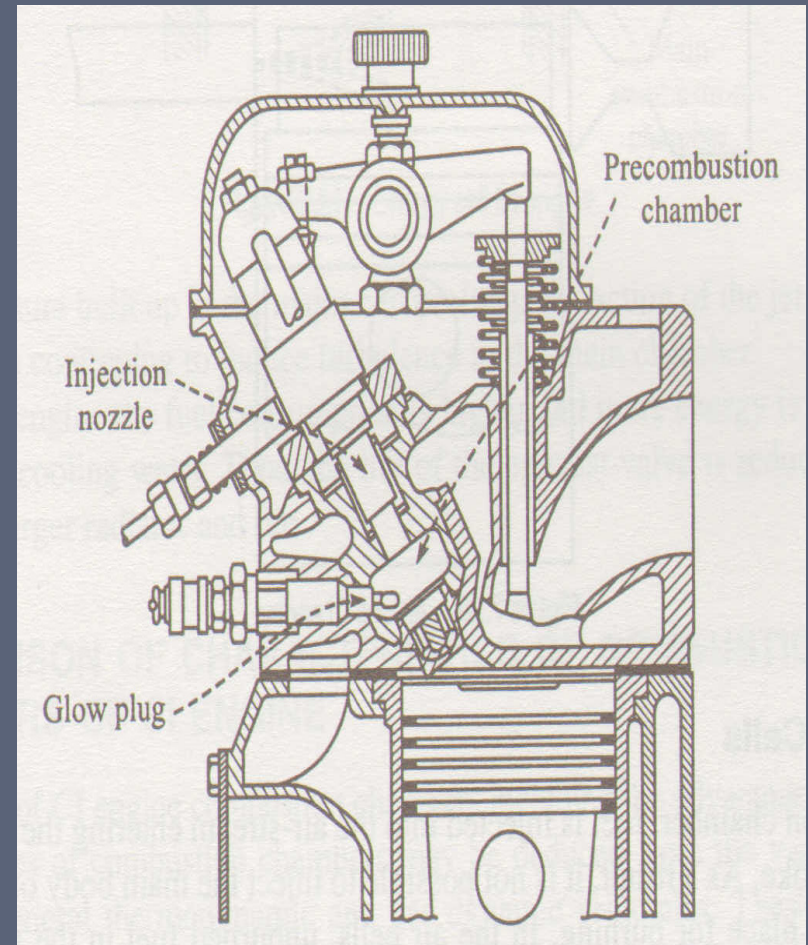

AIR CELLS

- The air cell type of combustion chamber does not depend upon the organized air-swirl like pre-combustion chamber.
- The air cell is a separate chamber used to communicate with the main chamber through a narrow restricted neck.
- The air cell contains 5 to 15 per cent of the clearance volume. Fuel is injected into the main combustion space and ejects in a jet across this space to the open neck of the air cell, as shown in Figure.
- Some fuel enters and ignites in the air cell.
- This raises the pressure in the air cell and the burning mixture is discharged into the main chamber.
- Some combustion also takes place in the main combustion chamber. Combustion is completed on the down-stroke of the piston while the air is discharged from the air cell into the partly burned mixture.

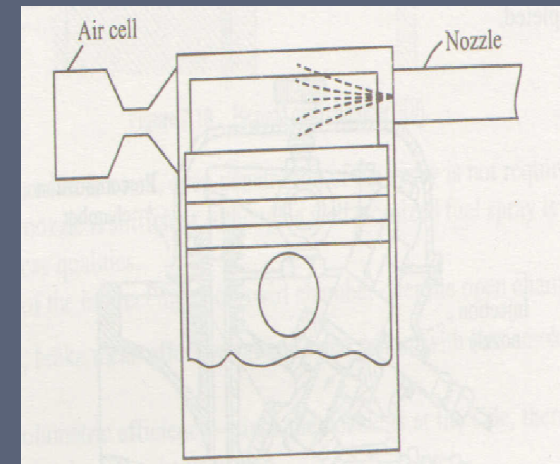

AIR CELLS

- The effective expansion ratio is curtailed and both the efficiency and the power output are reduced, but easy starting and reasonably smooth running are obtained with fairly low maximum pressures.
- It is best suited for small engines of medium duty where a relatively high fuel consumption can be tolerated.
- The air cell was considered unnecessary after it became possible to generate swirl in open chamber and therefore the air cell types of combustion chambers are now obsolete.

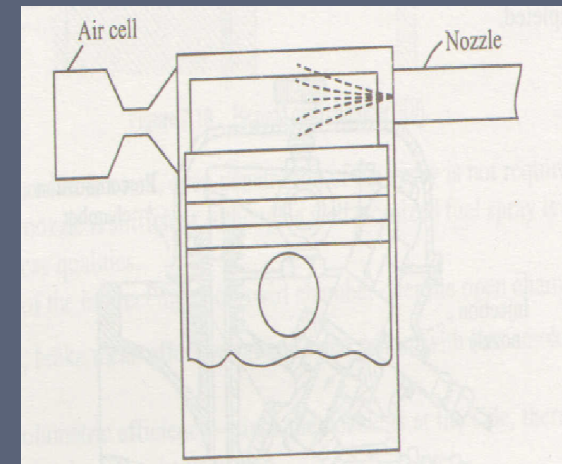

ENERGY CELLS

- In the pre-combustion chamber, fuel is injected into the air-stream entering the pre-chamber during the compression stroke.
- As a result, it is not possible to inject the main body of the fuel spray into the most important place for burning.
- In the air cells, un-burnt fuel in the main chamber may not find enough turbulence.
- These drawbacks can be overcome in the energy cells. It is a hybrid design between the pre-combustion chamber and the air cell.
- The energy cell contains about 10-15 % of the clearance volume. It has two cells, major and minor, which are separated from each other by a respective orifice.
- The energy cell is separated from the main chamber by a narrow restricted neck

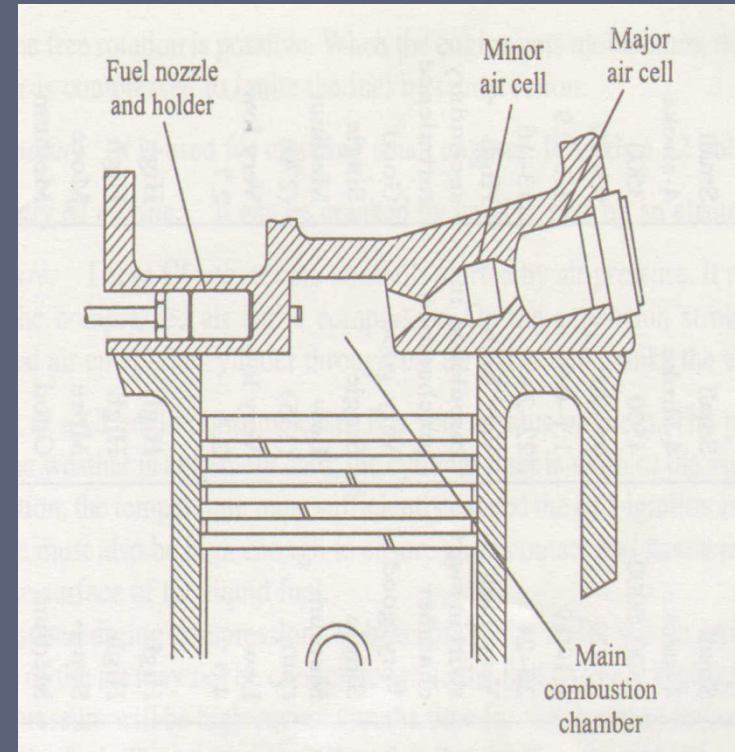

ENERGY CELLS

- As the piston moves up on the compression stroke, some of the air is forced into the major and minor chambers of the energy cell.
- When the fuel is injected through the pintle type nozzle, part of the fuel passes across the main combustion chamber and enters the minor cell, where it is mixed with the air entering during compression from the main chamber.
- Combustion first commences in the of burning at the start, but due to better mixing, progresses at a more rapid rate.
- The pressures built up in the minor cell, create added turbulence and produce better combustion in this chamber.
- In the mean time, the pressure built up in the major cell prolongs the action of jet stream entering the main chamber, thus continuing to induce turbulence in the main chamber.
- In this type of the engine, the fuel consumption is higher and more energy is carried away in the exhaust and cooling water. Thus the life of the exhaust valve is reduced and this engine requires larger radiator and fan.

